

Definition: (0.5)-20 UNS 3A
Major diameter: 0.5000 / 0.4919
Pitch diameter: 0.4675 / 0.4643
Minor diameter: 0.4405 / 0.4269

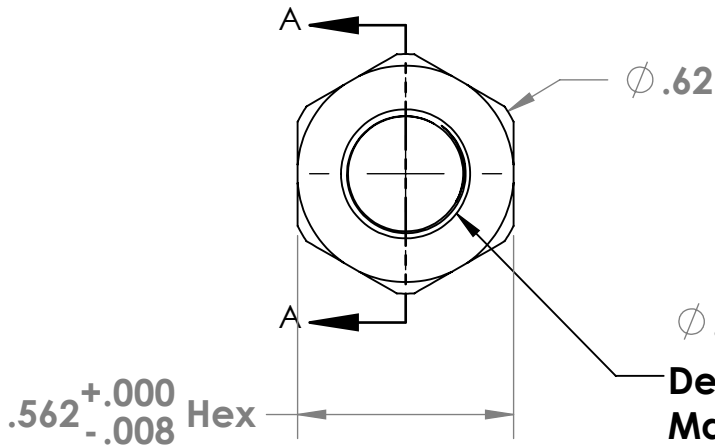
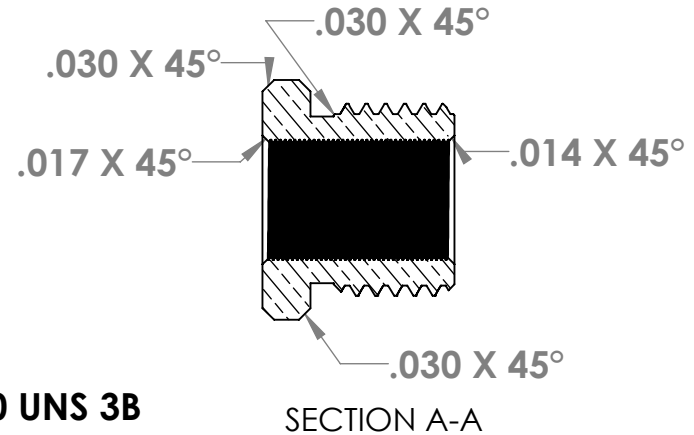
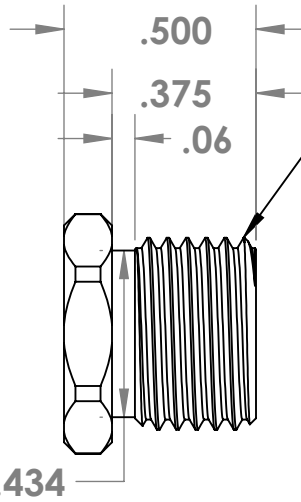

Definition: (0.3125)-80 UNS 3B
Major diameter: 0.3166 / 0.3125
Pitch diameter: 0.3067 / 0.3044
Minor diameter: 0.3016 / 0.2990

Note:

- Finish: 32RMS As Machined.**
- Threads must have no burrs, dings, or rolled over chamfer leads.**

PROPRIETARY AND CONFIDENTIAL
 THE INFORMATION CONTAINED IN THIS DRAWING IS THE SOLE PROPERTY OF Hitek Hardware, Inc. ANY REPRODUCTION IN PART OR AS A WHOLE WITHOUT THE WRITTEN PERMISSION OF Hitek Hardware, Inc. IS PROHIBITED.

		UNLESS OTHERWISE SPECIFIED:	NAME	DATE		
		DIMENSIONS ARE IN INCHES TOLERANCES: FRACTIONAL ± .015" ANGULAR: MACH ± .5° TWO PLACE DECIMAL ± .010 THREE PLACE DECIMAL ± .005 FOUR PLACE DECIMAL ± .0005	DRAWN		TITLE:	
		INTERPRET GEOMETRIC TOLERANCING PER:	CHECKED		Precision Bushing, 5/16-80 int Thd., 1/2-20 Ext. Thd, 9/16 Hex, Brass	
		MATERIAL 360 Brass	ENG APPR.			
NEXT ASSY	USED ON	FINISH	MFG APPR.		SIZE A	DWG. NO. PS312-80-20-CHB
APPLICATION		DO NOT SCALE DRAWING	Q.A.		REV 1	
			COMMENTS:		SCALE: 2:1	WEIGHT:
					SHEET 1 OF 1	